



# KALCO CORPORATION

A Kenneth Avery Lawson Company

## LAWSON HERITAGE | J - SERIES

### Journeyman "J" Series Flat Filler



The Lawson Heritage Journeyman Series container filling system is designed to provide growers with a versatile, compact, high speed and uniform solution to filling multiple types of containers including; pots, hanging baskets, flats and plug trays.

The J Series is the most durable high performance flat filler in its class, with features like a 12 gauge steel frame, 10 gauge steel incline and chain drag chamber; increasing thickness by as much as one third! Laser cut solid steel sprockets on drive & idler, along with steel machined guided lift rollers at the top of the incline. Variable speed fill conveyor control and adjustable gate for accurate soil delivery and high speed operation, all controlled by 110v input. You can put this machine virtually anywhere with a 110v Outlet.



### FEATURES

- 110v Input / 20 Amp
- Variable Speed Filling Conveyor
- Heavy Construction
- Steel Sprockets and Idler
- Standard Adjustable Chute
- Pivoting & Adjustable Sweeper
- Take Off Pot Stabilizer
- Hold Down Bar
- All Adjustments at Easy Access Levels
- Self Cleaning Conveyor System
- Adjustable Power Sweeper
- 1.6 Cubic Yard Tapered Gated Hopper
- Clean Outs at Both Ends of Filler
- Easy Adjust Guide Rails
- Standard Legs
- 1 Year Warranty

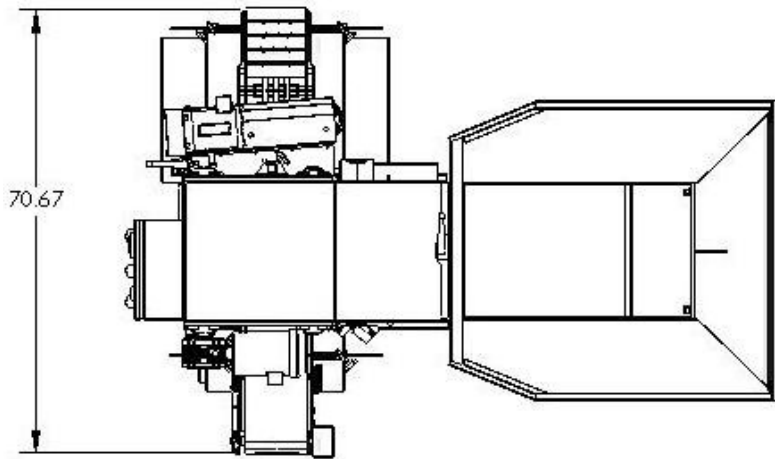
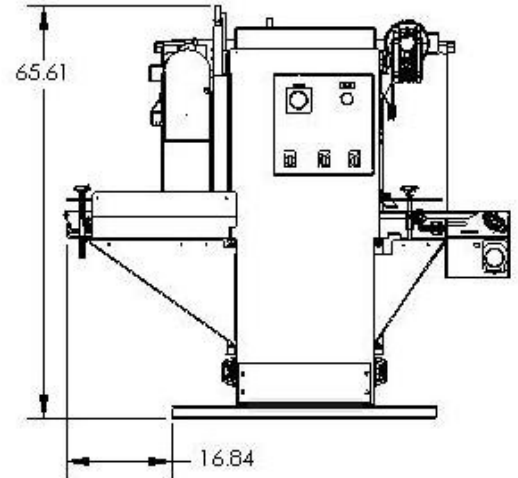
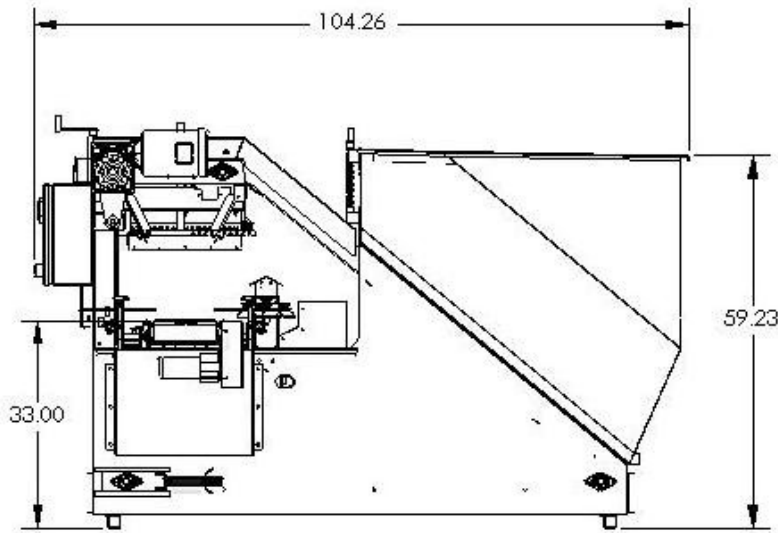

### ELECTRICAL SYSTEM

- Circuit Breakers Instead of Fuses
- UV Resistant Oflex Cable
- Variable Speed DC Conveyor
- Premium Grade Industrial Electronics
- Accurate Soil Delivery, Reduces the Amount of Soil that Recycles Back to the Hopper. This Reduces Pressure on the Soil Chain, Wear on Soil Delivery Parts and Stops the Grinding Affect on the Soil Mixture.

### OPTIONS

- Conveyor Vibrator
- Return Vibrator
- Power Take Off System
- Air Blow Off System.
- 8" Phenolic Caster Kit

**Kalco Corporation**  
**422 Old Nashville Hwy**  
**McMinnville, Tn. 37110**  
**Phone: 931-815-5252**  
**Website: [www.kalcocorp.com](http://www.kalcocorp.com)**